



# Government College of Engineering, Aurangabad Chhatrapati Sambhajnagar

Station Road, Osmanpura, Chh. Sambhajnagar

Phone : (0240) 2366101,2366110,111  
E-Mail – principalgeca@yahoo.com

Fax : (0240) 2332835  
Web – http://www.geca.ac.in

No. GECA/Gymkhana/2024-25/1324

Date 10/2 MAY 2024

To,

GECA Notice Board / GECA WEBSITE

## Subject :- Quotation for Supply of Furniture Item for Gymkhana Department

Dear Sir/madam, You are requested to send your competitive quotations are invited for eligible and interested dealers/distributors/Suppliers for the supply of the following items subject to the following conditions.

### Terms & Conditions -

- 1 Rates quoted should be free delivery at the Institute inclusive of all lead and Lift.
- 2 Detailed specifications of the articles you intend to supply should be given. If not according to the specification, laid down here under.
- 3.The material should be supplied within (07) days from the date of order. List of material is given below.
- 4.The earliest delivery period should be quoted if you cannot supply within the period mentioned above.
- 5.Quotation should be in sealed cover and superscripted as “**Quotations for Gymkhana Department**” Due on : 10-05-2024, at 5 P.M.
- 6.Quotation should be valid for six months.
- 7.Right to reject any or all quotations are reserved with the under signed.
- 8.Rates quoted must be inclusive of All applicable Taxes.
9. Delivery of the material will be carried out free of cost at our institute in Gymkhana by the supplier.
10. No advance shall be paid and No part payment shall be made.
- 11.Detail Specification including make of material should be mentioned in Quotation. If the quoted Item/Peripheral is available with you in different brands/makes, the rates should be mentioned separately brand wise/specification wise. **If the Make/Brand/Manufacturer name is not mentioned in the quotation will be rejected without giving any information to the supplier.**
- 12.Material will be inspected by the concerned department. If the material found correct subject to the required specifications, bill will be passed, otherwise returned as it is at your cost
- 13.GST Certificate, Authorized Dealers /distributers /Suppliers Certificate, and other related certificate is attached.
- 14.Quotation not complying with the above conditions and incomplete once will not be considered

Sr. no.	Name of item	Quantity	Rate Per Unit Including GST
1	Office Table L Type (as per attached Image )	1	
2	Revolving Office Chair (as per attached Image )	1	
3	Office Chair (as per attached Image )	6	
4	Cupboard for Trophy (as per attached Image )	2	

Yours faithfully

  
Principal

Govt. College of Engineering, Aurangabad  
Chharrapati Sambhainagar

## Gymkhana Dept

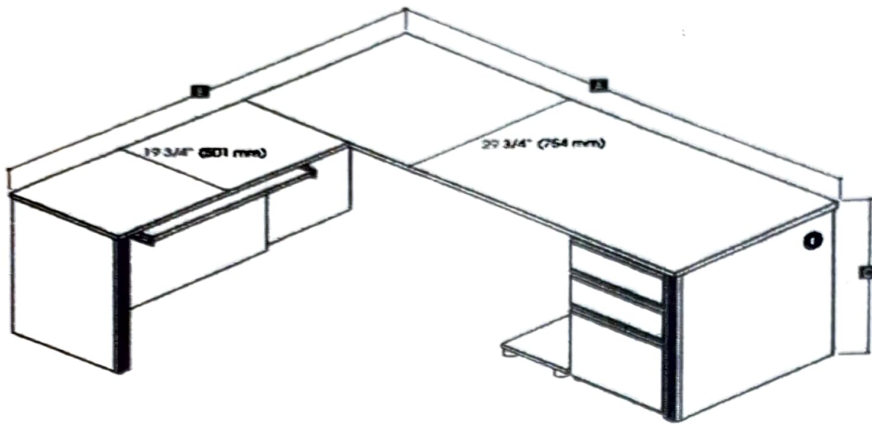

Material :- Wood Base - Particle board  
(18 mm Ply)

L Type Office Table



Revolving Office Chair



Office Chair



**Size (Hight-7 Ft Length-5ft Depth -1.5)**

**Material for the Trophy rack :- plywood or wood base particle board  
( Trophy rack made in plywood will be preferred)**

**Kindly quote cost of trophy rack using both the materials if available**